

# LED Channel Module

Bandis Vision's Channel Sign solutions run on a 12 Volt system with 'Built in Constant Current' One should note that the conformal coated PCBs are moisture and humidity resistant modules, and are available in pre-wired strings with genuine 3M VHB tape on the back of each module.

## Features and Benefits

- 2-LED per module; 3 LED chips in a package
- 2 modules per 10 Inch
- Long life. 70,000 Hours/10 years LED
- Brilliant uniform color temperature
- Up to 80% more energy efficient than conventional fluorescent lamp
- 0.5W per module (100 modules per 60 W power supply)
- Built in Constant Current
- Easy to install with 3M VHB tape on the back of each module
- Waterproof
- 3 Years warranty



Authorized Distributor:

**SPECTRAL** lighting systems

Web: [www.spectrallv.ca](http://www.spectrallv.ca) | Ph: 905-751-8490 | Fx: 905-836-6772

**Bandis**  
VISION

# LED Channel Module

## Physical Dimension / Specifications

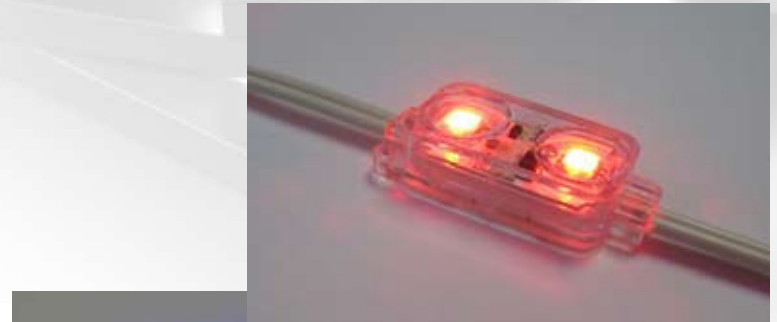
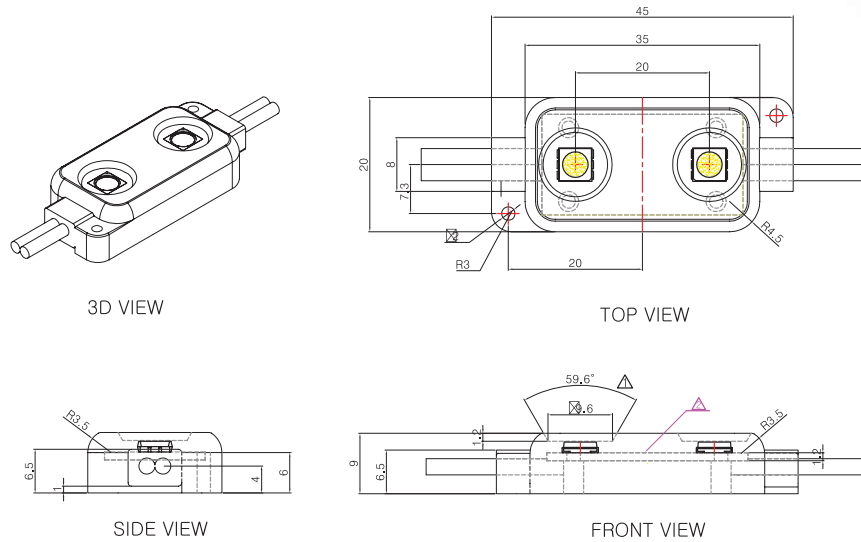

Colour	White, Red, Green, Blue
Viewing Angle	120
Length	1.77 inch per module
LED Quantity	2 LEDs per module / 6 LED Chips per module
Power Consumption	0.54W
Amps	45 mA
Input Voltage	12V DC
Operating Tem	-30 ~ 60 C



Authorized Distributor:

**SPECTRAL** lighting systems

Web: [www.spectrallv.ca](http://www.spectrallv.ca) | Ph: 905-751-8490 | Fx: 905-836-6772

**Bandis**  
VISION